

Drill Cutting Bins



Container Bases - Australia

Ferguson Seacabs Pty Ltd
24/7 Tel: + 61 (0) 413 798 688

Perth Office

124 Quill Way, Henderson, WA, 6166
Tel: + 61 (0) 8 9410 5454 Fax: + 61 (0) 8 9437 9904
General email: perth@fergusonseacabs.com.au

Dampier Office

King Bay Road, Dampier, WA 6713
Tel: + 61 (0) 8 9144 2611 Fax: + 61 (0) 8 9144 2633
General email: dampier@fergusonseacabs.com.au

Darwin Office

Lot 1703 McKinnon Road, Pinelands, NT. 0828
Tel: + 6 (0) 8 8932 8700 Fax: + 61 (0) 8 8932 8788
General email: darwin@fergusonseacabs.com.au

Also represented in Victoria

International Bases

Head Office

Ferguson Group Limited
Harlaw Drive
Inverurie
Aberdeen AB51 4SF
Scotland
Tel: + 44 (0) 1467 626500
Fax: + 44 (0) 1467 626559
email: info@fergusonmodular.com

Container Base - Singapore

Ferguson Seacabs Pte Ltd
Tel: + 65 6545 4700
Town Office
Tel: + 65 6549 7714
email: containers@fergusonseacabs.com.sg

Container Base - Scotland

Ferguson Seacabs Ltd, Aberdeen
Tel: + 44 (0) 1224 706464
email: containers@fergusonseacabs.com

Container Bases - Norway

Ferguson Norge AS
Tananger, Norway
Tel: + 47 51 64 79 00
email: ferguson@fergusonnorge.no
Bergen (CCB, Agotnes)
Tel: + 47 56 31 40 90
email: ferguson@fergusonnorge.no

Also in Florø and Kristiansund
email: ferguson@fergusonnorge.no

Also represented in New Zealand, Dubai, Qatar,
Trinidad, Malta, Libya

- Provide safe and efficient containment of drilling waste for transportation to treatment or disposal sites
- All units designed, manufactured and fully certified to DNV 2.7-1 / EN 12079 standards
- Designed to meet Norsok S-002N requirements to improve health and safety
- Light aluminium lid (max 25kg) for safe and easy lifting, opening/closing
- Due to design there is no need for climbing on units - eliminating risk of falls
- Large lid ensures ability to fill unit to maximum
- Sealed lid prevents any spillages during transportation
- When stacked two high the sling on the upper skip is easily accessible
- Forklift pockets for easy manoeuvring
- Designed for stability - tested up to 32 degrees

Dimensions

A	B	C
2213mm	1852mm	1617mm
7ft 3ins	6ft 1ins	5ft 4ins
(1ft = 0.305m)		

Tare

1700kgs

Payload

9300kgs

Rating

11000kgs

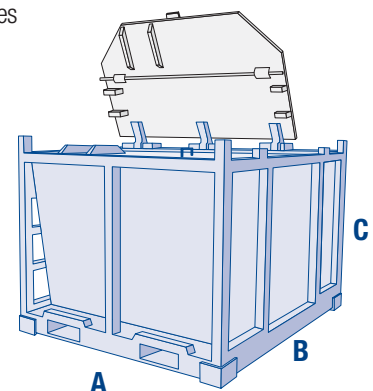

Products Available

Full Range of Containers, Cargo Baskets, Half Heights, Open Tops, Cargo Boxes, Gas Bottle Racks, Drill Cutting Bins, Waste Units, Compactors, Pipe Baskets, Workshop Units, Tubular Transportation Frames, A60 Modules and Offshore Chemical and Helifuel Tanks.



providing containers
around the world

www.fergusonseacabs.com.au

